

ITEM	DESCRIPTION
1	AIR DISCHARGE TOP PLATE / WEATHERHOOD
2	V-CLAMP, SS TOP
3	PLATE, FILTER HOLD DOWN
4	PULSE TUBE WITH ELBOW
5	FILTER CARTRIDGE

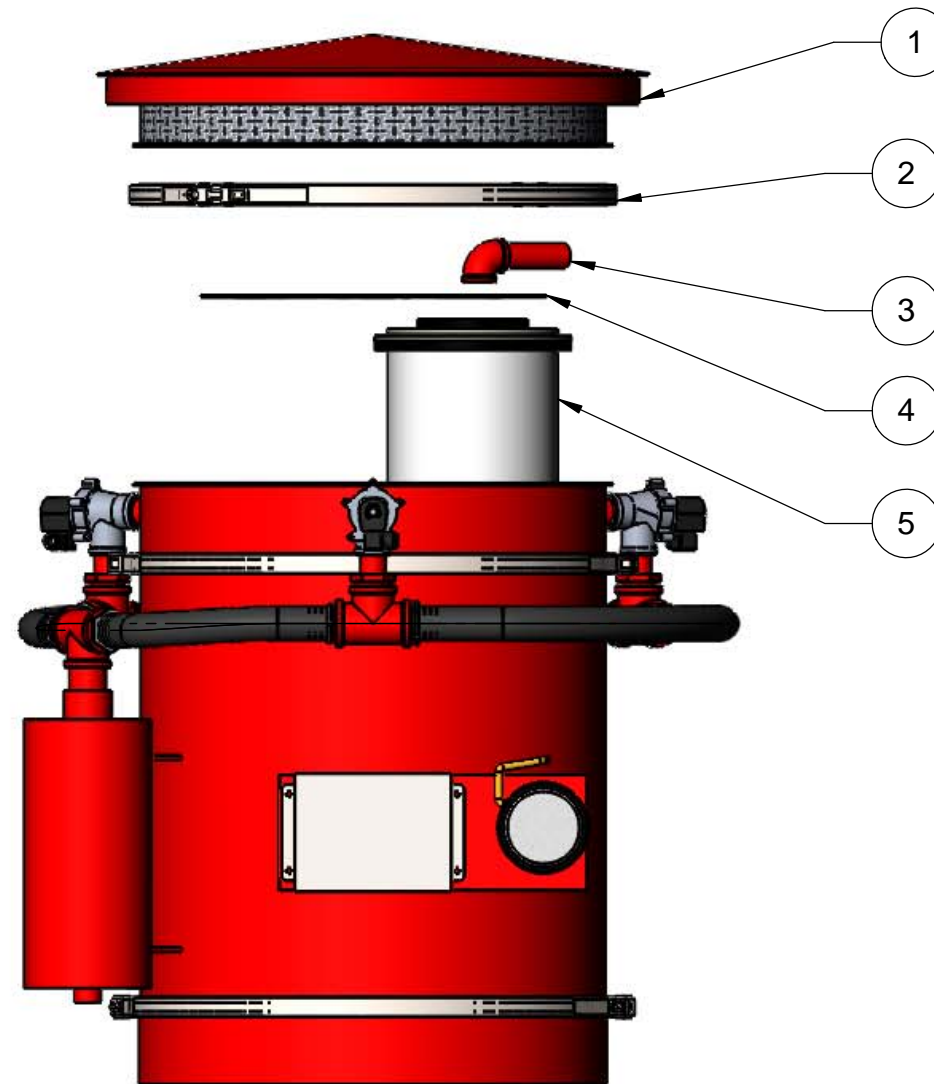
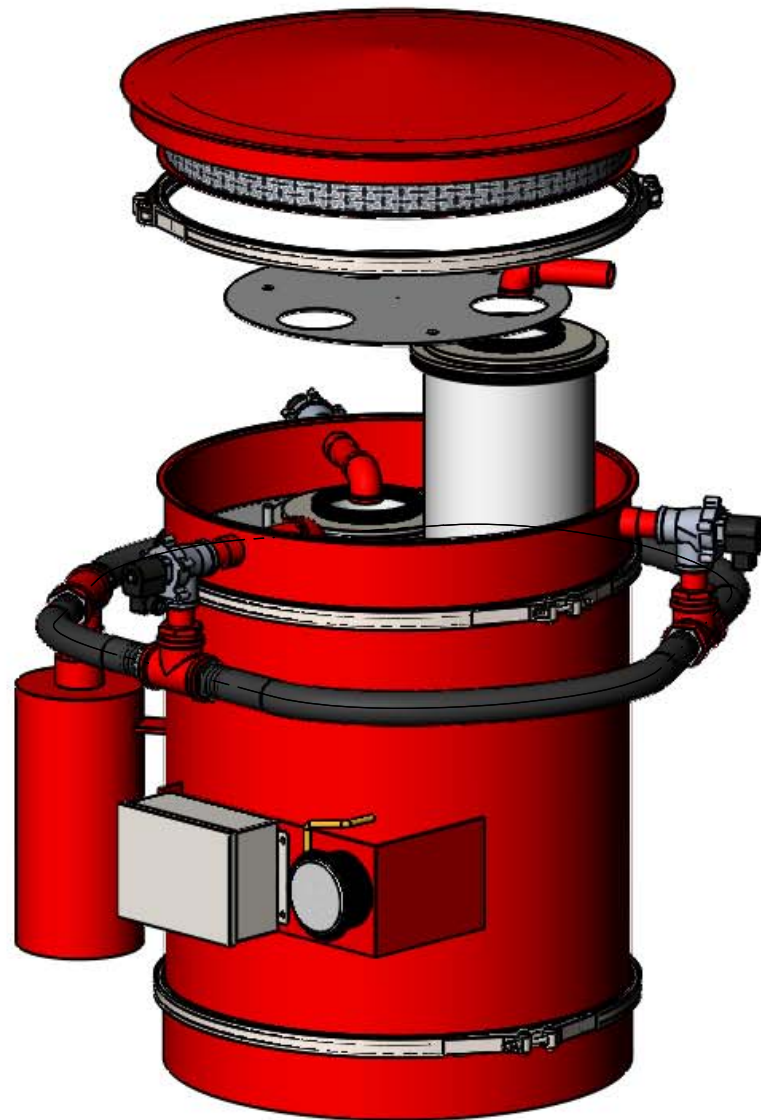

***** WARNING *****

PRIOR TO CARTRIDGE REMOVAL:
 -CUT AIR SUPPLY FEEDING COMPRESSED AIR HEADER
 -DRAIN ANY COMPRESSED AIR FROM HEADER
 -INSURE NO AIR OR MATERIAL IS BEING BLOWN INTO THE BIN THAT THE BIN VENT IS MOUNTED ON

CARTRIDGE REMOVAL

1. REMOVE TOP V-CLAMP (ITEM 2)
2. REMOVE AIR DISCHARGE TOP (ITEM 1)
3. REMOVE AIR PULSE TUBES WITH ELBOW (ITEM 3)
4. REMOVE HOLD DOWN PLATE (ITEM 4)
5. REMOVE FILTER CARTRIDGES (ITEM 5)

CARTRIDGE INSTALLATION

1. INSERT NEW CARTRIDGES (ITEM 5)
2. INSTALL FILTER HOLD DOWN PLATE (ITEM 4)
 ** TIGHTEN FILTER HOLD DOWN NUTS IN A RANDOM PATTERN TO INSURE FILTER CARTRIDGE GASKETS COMPRESS EVENLY.
3. INSTALL PULSE TUBES WITH ELBOW (ITEM 3)
 **INSURE PULSE TUBE ELBOW IS ORIENTED 90 DEG. DIRECTLY DOWN THE CENTER OF THE FILTER CARTRIDGE.
4. INSTALL AIR DISCHARGE TOP (ITEM 1)
5. REPLACE TOP V-CLAMP (ITEM 2)



Dense Flow

PALM HARBOR, FLORIDA U.S.A.
 727-785-8500

TITLE : ROUND BIN VENT CARTRIDGE REMOVAL

DRAWN XXXX	DATE 11/16/2016	DRAWING NO. XXXX
CHECKED XXXX	SCALE 1:24	

THIS DRAWING & DESIGN IS THE PROPERTY OF J.D.B. DENSE FLOW INC, AND SHOULD NOT BE REPRODUCED, PUBLISHED, OR DISCLOSED TO OTHERS WITHOUT WRITTEN AUTHORIZATION FROM J.D.B. DENSE FLOW AND SHALL BE IN NO WAY USED AGAINST OR DETRIMENTAL TO J.D.B. DENSE FLOW INC.